

# CLADDING FIELD SURVEY

CAB - ONE SPEED SIDE OPENING - LEFT HAND RETURN



info@fabacab.com  
800.800.4960

1600 Main Street  
Anderson, IN 46016

JOB NAME: \_\_\_\_\_

SURVEYOR NAME: \_\_\_\_\_

SURVEYOR PHONE NUMBER: \_\_\_\_\_

CAPACITY: \_\_\_\_\_ lbs.

ELEVATOR NUMBER: \_\_\_\_\_

### Survey Tips:

- 1) Send pictures.
- 2) No "rolling tape" measurements.
  - a. Make mark and measure to it.
- 3) Look for tapers in walls/jambes/strikes/returns.
- 4) Send C.O.P. dimensions.
- 5) Measure strike/return heights from threshold or smallest measurement, including cab floor.

### 1. Transom: (Complete section entirely and enter all dimensions in inches, not feet)

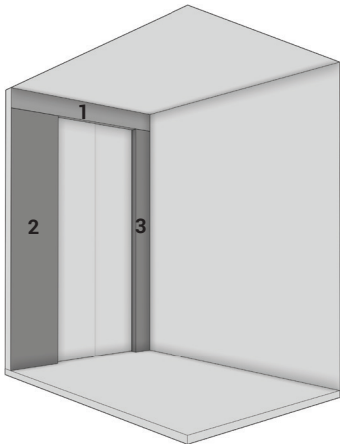

\*As an industry standard, surveys are conducted from within the car looking out.

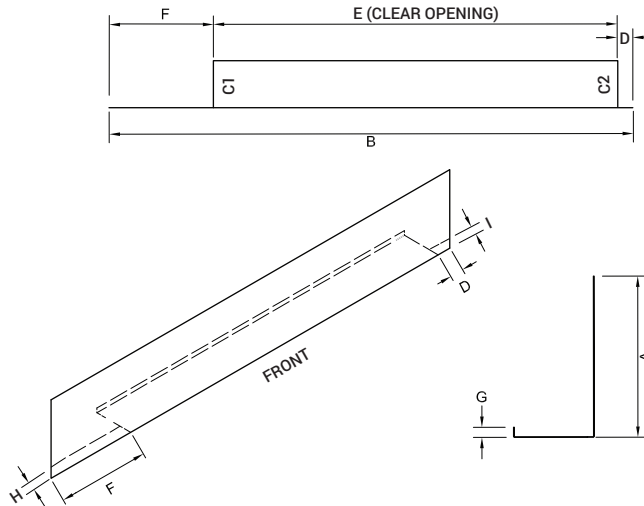

- A: \_\_\_\_\_"
- B: \_\_\_\_\_"
- C1: \_\_\_\_\_"
- C2: \_\_\_\_\_"
- D: \_\_\_\_\_"
- E: \_\_\_\_\_"
- F: \_\_\_\_\_"
- G: \_\_\_\_\_"
- H: \_\_\_\_\_"
- I: \_\_\_\_\_"

### 2. Return: (Complete section entirely and enter all dimensions in inches, not feet)

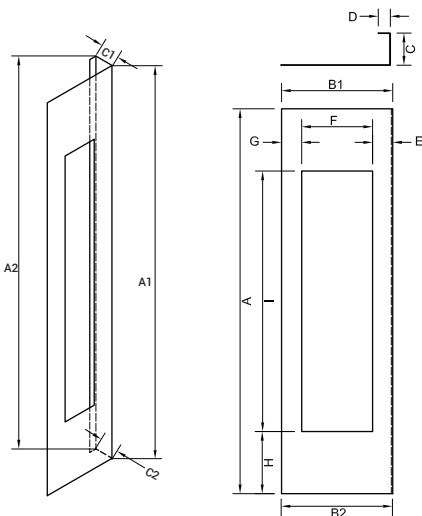

- A1: \_\_\_\_\_"
- A2: \_\_\_\_\_"
- B1: \_\_\_\_\_"
- B2: \_\_\_\_\_"
- C1: \_\_\_\_\_"
- C2: \_\_\_\_\_"
- D: \_\_\_\_\_"
- E: \_\_\_\_\_"
- F: \_\_\_\_\_"
- G: \_\_\_\_\_"
- H: \_\_\_\_\_"
- I: \_\_\_\_\_"

### 3. Strike: (Complete section entirely and enter all dimensions in inches, not feet)

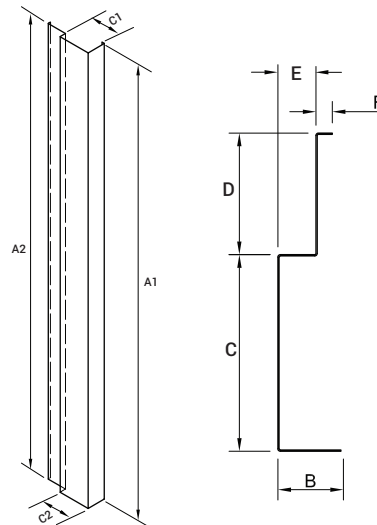

- A1: \_\_\_\_\_"
- A2: \_\_\_\_\_"
- B: \_\_\_\_\_"
- C1: \_\_\_\_\_"
- C2: \_\_\_\_\_"
- D: \_\_\_\_\_"
- E: \_\_\_\_\_"
- F: \_\_\_\_\_"

FABRICATION APPROVAL SIGNATURE: \_\_\_\_\_

(A signature serves as the final approval of the above dimensions)