

# ANDROS



FABACVB

INSTALLATION INSTRUCTIONS:  
ANDROS PANEL SYSTEM

## 4 STEP PROCESS:

1. General Guidelines
2. Reveal Installation
3. Panel Installation
4. Rail Installation

## NEED MORE HELP?

### WATCH A VIDEO TUTORIAL:

1. Open the Camera app.
2. Scan Q.R. Code.
3. Select the link.

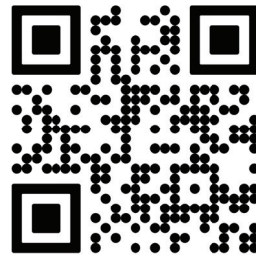

**24 HOUR TECHNICAL HOTLINE: 800.800.4960**

Our staff is always ready to answer any questions, night or day.

### SPECIAL NOTES:

---

---

---

---

---

---

---

---

---

---

# 1 ANDROS PANEL SYSTEM GENERAL GUIDELINES

**TIP:** Always inspect the product for shipping damage before demolition of the existing cab interior. If any damage is found, please take photos and contact our 24 hour technical hotline detailing the extent of the damage.



1.1 Review 'customer drawings' and 'packing list'.

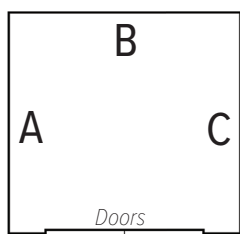
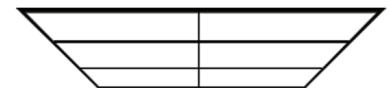

Figure 1.2

1.2 Elevation A,B & C represent walls as viewed from inside the cab looking out as shown in Figure 1.2.

1.3 Demo existing cab interior components including wall panels, hand rails, reveals, and mounting brackets.

1.4 If you are replacing the ceiling please follow the ceiling installation instructions provided in a separate document in your hardware kit as shown in Figure 1.4. This should be completed prior to installing the wall panel system.



Install Ceiling First

Figure 1.4

**TIP:** Ensure you have all the required tools before installing.  
Please follow Personal Protective Gear requirements for your region.



# 2 ANDROS PANEL SYSTEM REVEAL INSTALLATION

## 2.1 Install Base Reveals.

**TIP:** If you have ordered Black Finish reveals, ensure to hide the holes on the reveals behind the panels. (These holes are used for powder coating purposes.)

Our standard base reveal is 5" tall and ½" shorter than the width of each cab wall.

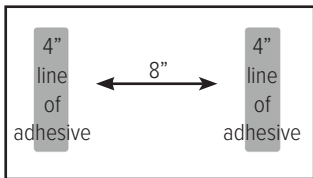

Figure 2.1.1

2.1.1 Apply adhesive on base reveal as shown in Figure 2.1.1.

2.1.2 Center the reveal against the wall along the floor and apply light pressure to distribute the adhesive evenly as shown in Figure 2.1.2.

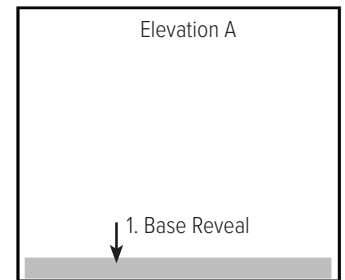

Figure 2.1.2

2.1.3 Repeat steps 2.1.1 through 2.1.2 for Elevation "B" and "C", as applicable.

## 2.2. Install Front Vertical Reveals.

**TIP:** Our standard front vertical reveal is 2" wide and has a length that will reach from the floor of the cab to the top of the highest wall panel.

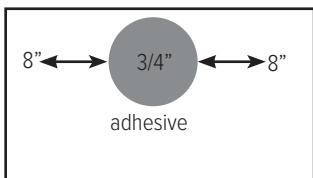

Figure 2.2.1

2.2.1 Apply adhesive on front vertical reveals as shown in Figure 2.2.1.

2.2.2 Place the front vertical reveal on the floor, against the wall & over existing base & apply light pressure to the length of it as shown in Figure 2.2.2.

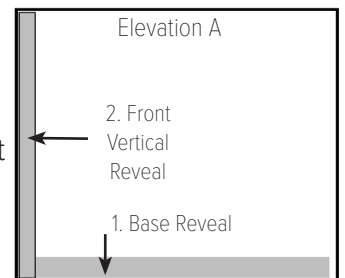

Figure 2.2.2

2.2.3 Repeat steps 2.2.1 through 2.2.2 for Elevation "B" & "C", as applicable.

## 2.3 Install Corner Reveals.

**TIP:** Our standard corner reveal is 2" wide in both directions from the corner and has a length that will reach from the floor of the cab to the top of the highest wall panel.

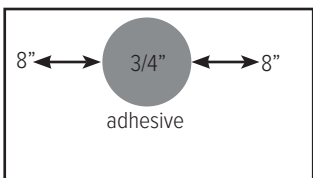

Figure 2.3.1

2.3.1 Apply adhesive on corner reveals as shown in Figure 2.3.1.

2.3.2 Place the corner reveal on the floor, against the wall & over existing base & apply light pressure to the length of it as shown in Figure 2.3.2

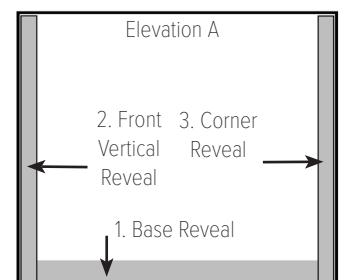

Figure 2.3.2

2.3.3 Repeat steps 2.3.1 through 2.3.2 for Elevation "B" and "C", as applicable.

# 3 ANDROS PANEL SYSTEM

## PANEL INSTALLATION 1/2

**TIP: Be sure to drill ventilation holes as required by your jurisdiction.**

### 3.1 Install the Aluminum J-Channel.

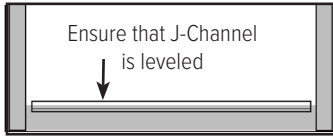

Figure 3.1.1

**TIP: It is extremely important that the J-channel is level on each wall and level from wall to wall.**

3.1.1 Set the J-channel on the base reveal, center it on the wall and level it as shown in Figure 3.1.1.

3.1.2 The J-Channel overlaps the base reveal by 1" as shown in Figure 3.1.2.

3.1.3 If the J-channel is level, fasten it to the cab shell using the #10 x 3/4 inch self-tapping screws provided in the hardware kit.

3.1.4 If the J-channel is not level, find the high end of the channel and fasten it to the cab shell using a self-tapping screw mentioned above.

3.1.5 Bring the low end of the J-channel up to level and fasten to the cab shell.

3.1.6 Repeat steps 3.1.1 through 3.1.5 for Elevation "B" & "C".

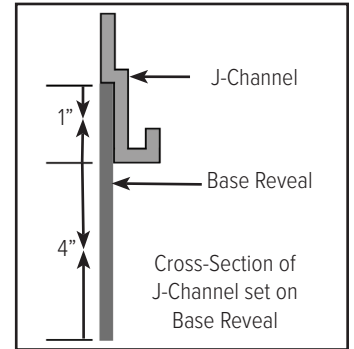

Figure 3.1.2

### 3.2 Install Horizontal Panels.

**TIP: We recommend installing the bottom panel on all walls before any of the upper or accent panels. This is to ensure all panels are level with the adjacent panels on all walls.**

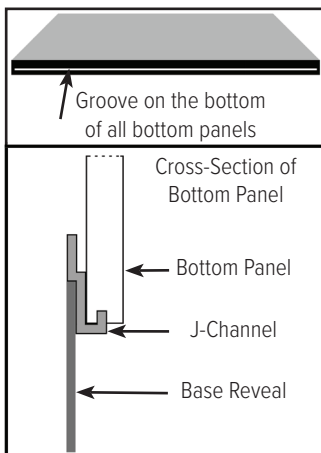

Figure 3.2.1

3.2.1 Set Bottom panel groove on the J-Channel as shown in Figure 3.2.1.

3.2.2 Center the A-1 panel on the wall as shown in 3.2.2

3.2.3 Fasten the top of the panel to the cab shell with the provided screws.

3.2.4 Place Panel "A-2" flush on top of Panel "A-1" as shown in Figure 3.2.4. Fasten the top of the panel to the cab shell. Repeat steps for panels A-3 and A-4.

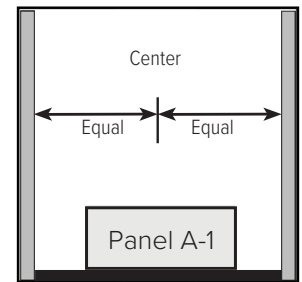

Figure 3.2.2

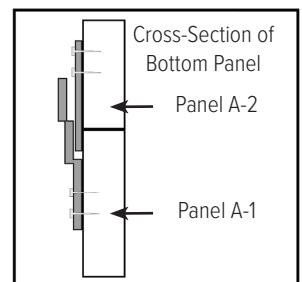

Figure 3.2.4

# 3 ANDROS PANEL SYSTEM

## PANEL INSTALLATION 2/2

### 3.3 Install Wall Template.

**TIP:** Templates are required for vertical panels to locate the mounting clips on the cab walls. Your wall kit includes one template for all accent panels.

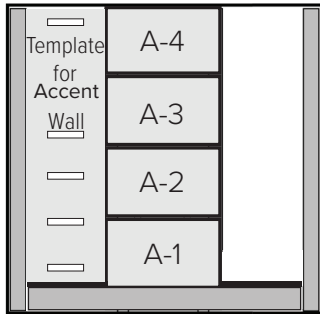

Figure 3.3.1

3.3.1 Place accent wall panel template on J channel as shown in [Figure 3.3.1](#).

3.3.2 Plumb the template tight against panel A-1 through A-4 and screw it to the wall. It is extremely important that each panel is level for proper alignment.

### 3.4 Install Z-Clips and Vertical Wall Panels.

**TIP:** The system is designed for the vertical panels to sit tight against the horizontal panels as shown in [Figure 3.4](#).

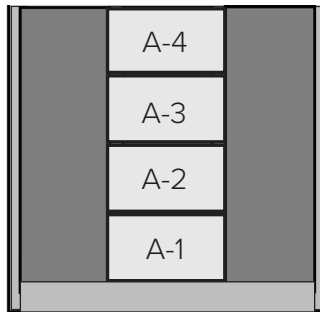

Figure 3.4

3.4.1 Fasten Z-clips to the cab shell at each open slot in the template as shown in [Figure 3.4.1](#). Z-clip is approximately 8" shorter than panel width.

3.4.2 Be sure that the Z-clip does not rotate when you tighten the mounting screws as this will result in mis-alignment with the mating Z-clip.

3.4.3 After all Z-clips are installed, remove the screws holding the template in place and move the template over to the opposite corner of B wall.

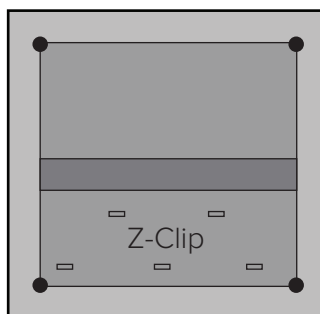

Figure 3.4.1

3.4.4 Repeat steps "3.3.1" through "3.4.3" for all of the remaining panel clips on elevations "A","B" and "C".

3.4.5 Locate the wall panels for each wall to install them. Apply a small dab of adhesive on a couple of Z-Clips to avoid vibrations. Install the vertical panel by lifting the panel above the Z-clips, inserting the male (vertical) bracket into the female (vertical) bracket, then slide the panel down to interlock the Z-clips and the J-Channel along bottom of the panel.

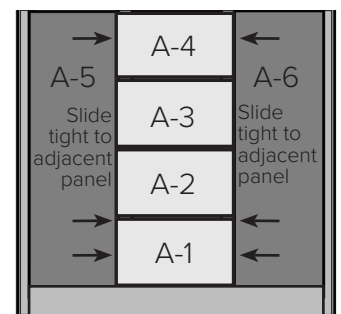

Figure 3.4.6

3.4.6 Be sure to slide the vertical panels tight to adjacent wall panels. Vertical male bracket will interlock with vertical female bracket, so that there will not be any separation between the wall panels. See [Figure 3.4.6](#).

# 4 ANDROS PANEL SYSTEM

## RAIL INSTALLATION

### 4.1 Install the Hand Rail.

**TIP: If your panel system was ordered with hand rails, the wall panels will have pre-drilled holes at each stand off location. The holes are 7/16" in diameter.**

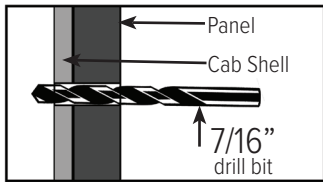

Figure 4.1.1

4.1.1 Drill a 7/16" hole in the cab shell at each panel hole location as shown in Figure 4.1.1.

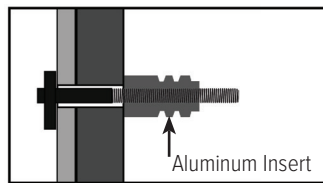

Figure 4.1.2

4.1.2 Insert a 3/8" T-bolt through the hole and push the stud in until the toggle drops outside of the elevator cab shell as shown in Figure 4.1.2. Apply a few drops of Loctite to the threads.



Figure 4.1.3

4.1.3 Thread the 3/4" aluminum insert onto the T-bolt as shown in Figure 4.1.3.

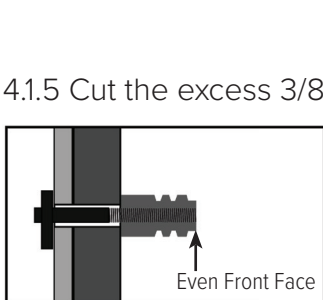

Figure 4.1.4

4.1.4 Tighten the aluminum insert using a 5/8" wrench on the flats of the aluminum insert.

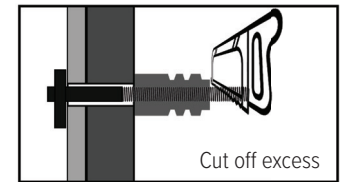

Figure 4.1.5

4.1.5 Cut the excess 3/8" stud off with a hacksaw as shown in Figure 4.1.5.

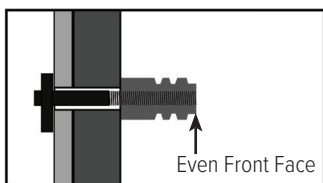

Figure 4.1.6

4.1.6 Make sure the front face of the aluminum insert is flush with the T-Bolt as shown in Figure 4.1.6.

4.1.7 Repeat steps 4.1.1 through 4.1.6 for all remaining mounting holes.

**TIP: The two allen set screw holes located on each hand rail stand off should be facing down and not be visible from the top.**

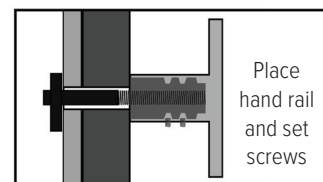

Figure 4.1.8

4.1.8 Locate the correct hand rail for wall "A" and slide the hand rail stand offs over the aluminum inserts until the stand offs are tight against the wall panel as shown in Figure 4.1.8.

4.1.9 Insert two allen set screws into each stand off and tighten using a 5/64" allen wrench as shown in Figure 4.1.9.

4.1.10 Make sure the hand rail is pushed tight against the panel before tightening set screws. Allen set screws will recess completely if hand rail is completely installed.

4.1.11 Repeat steps 4.1.8 through 4.1.10 for the remaining hand rails.

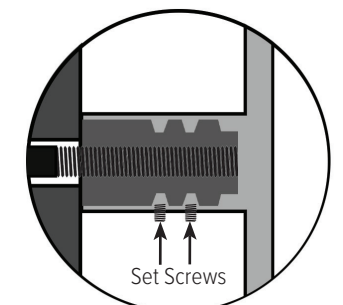

Figure 4.1.9

### 4.2 Install the Bumper Rail.

4.2.1 For bumper rail installation, repeat steps 4.1.1 through 4.1.10.

