

**REFLECTED CEILING VIEW**  
A VIEW OF THE CAB AS IF LOOKING FROM ABOVE, THROUGH THE CEILING

**PLAN VIEW**

PARTS LIST & FINISH SELECTION				
ITEM	DESCRIPTION	MATERIAL	QTY	WEIGHT / lbs
1	CEILING	ANEGADA: BRUSHED ALUMINUM T-FRAME (1.50"X1.50"X.125") CEILING COATED IN CLEAR LACQUER WITH (6) 14 GAUGE STAINLESS STEEL #4 FINISH DROP IN PANELS	1	85.679
2	LIGHTING	SOLOBEAM-6: LED DOWN LIGHTING SYSTEM BY MAN-D-TEC. DIE-CAST SMOOTH BLACK FINISH FIXTURES	1 (SET)	8.6642
3	UPPER WALL PANELS	HORIZONTAL PANEL SYSTEM CONSISTING OF (3) 1/2" FRPB PANELS FACED WITH WILSONART CRYSTAL D388-60 LAMINATE. ALL PANELS ARE BANDED IN BLACK PVC EDGE BANDING	3	80.9667
4	MIDDLE WALL PANELS	HORIZONTAL PANEL SYSTEM CONSISTING OF (3) 1/2" FRPB PANELS FACED WITH WILSONART HIGH LINE 7970K-18 LAMINATE. ALL PANELS ARE BANDED IN BLACK PVC EDGE BANDING	3	80.9667
5	HANDRAIL WALL PANELS	HORIZONTAL PANEL SYSTEM CONSISTING OF (3) 1/2" FRPB PANELS FACED WITH WILSONART CRYSTAL D388-60 LAMINATE. ALL PANELS ARE BANDED IN BLACK PVC EDGE BANDING	3	23.1333
6	LOWER WALL PANELS	HORIZONTAL PANEL SYSTEM CONSISTING OF (3) 1/2" FRPB PANELS FACED WITH WILSONART HIGH LINE 7970K-18 LAMINATE. ALL PANELS ARE BANDED IN BLACK PVC EDGE BANDING	3	66.5083
7	BACK HANDRAIL	3/8" X 2.00" FLAT S/S, #4 FINISH WITH RETURNED ENDS. STANDARD, FLAT FACE STANDOFFS	1	14.1844
8	SIDE HANDRAIL	3/8" X 2.00" FLAT S/S, #4 FINISH WITH RETURNED ENDS. STANDARD, FLAT FACE STANDOFFS	2	16.3094
9	RECESSED BASE & REVEALS	20 GAUGE STAINLESS STEEL #4 FINISH	1 (SET)	22.3755

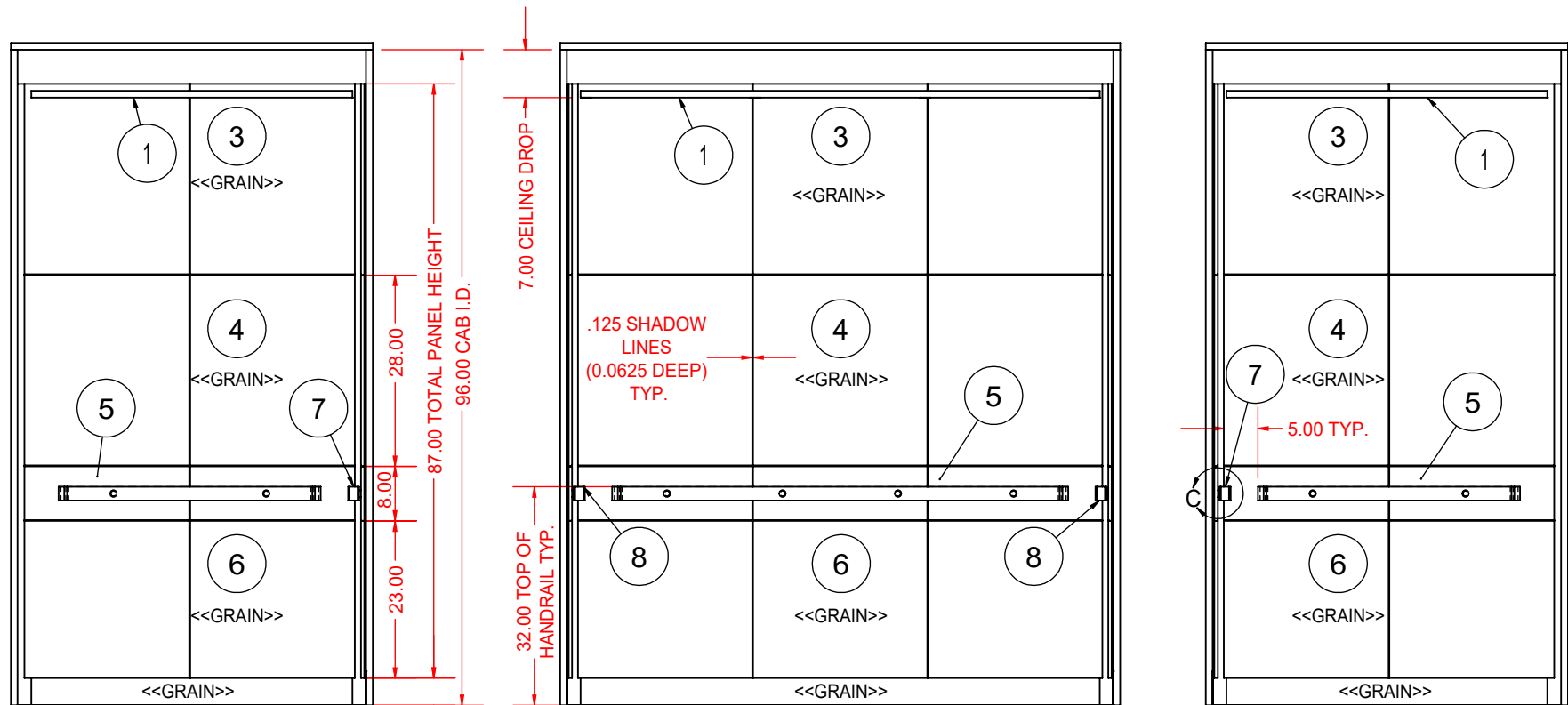

**WALL ELEVATION A**

**WALL ELEVATION B**

**WALL ELEVATION C**

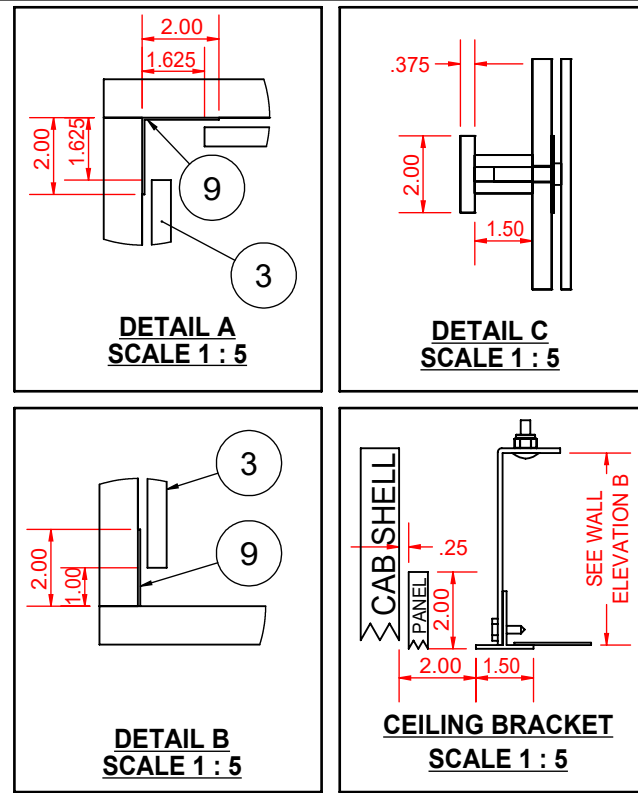

**DETAIL A**  
SCALE 1 : 5

**DETAIL C**  
SCALE 1 : 5

**DETAIL B**  
SCALE 1 : 5

**CEILING BRACKET**  
SCALE 1 : 5



8896 West State Rd. 236  
Middletown, IN 47356  
T: 800.800.4960

F.A.C. JOB NUMBER: XXXXX	CAPACITY: 2500 lbs	JOB NAME: JOB NAME HERE
CAB I.D.: CAB XX		CONTACT: YOUR NAME HERE!
WALL PANELS: SANTA CRUZ		CEILING TYPE: ANEGADA T-FRAME
SALES REP: SALES REP NAME HERE	DATE: XX/XX/20XX	DRAWING SCALE: 1 : 25
REVISIONS:	FABRICATION APPROVAL SIGNATURE:	

SPECIFIC PRODUCT NOTES		UNIT CONVERSION	
ALL DIMENSIONS ARE GIVEN IN INCHES		1/2 = 0.5000	9/16 = 0.5625
(ALL DIMENSIONS ±1/32")		1/8 = 0.1250	5/8 = 0.6250
QTY: 1 CAB		3/16 = 0.1875	11/16 = 0.6875
		1/4 = 0.2500	3/4 = 0.7500
		5/16 = 0.3125	13/16 = 0.8125
		3/8 = 0.3750	7/8 = 0.8750
		7/16 = 0.4375	15/16 = 0.9375



IMAGE FOR ILLUSTRATION  
PURPOSES ONLY,  
COLOR SHADES AND  
PROPORTIONS MAY VARY

PARTS LIST & FINISH SELECTION				
ITEM	DESCRIPTION	MATERIAL	QTY	WEIGHT / lbs
1	CEILING	ANEGADA: BRUSHED ALUMINUM T-FRAME (1.50"X1.50"X.125") CEILING COATED IN CLEAR LACQUER WITH (6) 14 GAUGE STAINLESS STEEL #4 FINISH DROP IN PANELS	1	85.679
2	LIGHTING	SOLOBEAM-6: LED DOWN LIGHTING SYSTEM BY MAN-D-TEC. DIE-CAST SMOOTH BLACK FINISH FIXTURES	1 (SET)	8.6642
3	UPPER WALL PANELS	HORIZONTAL PANEL SYSTEM CONSISTING OF (3) 1/2" FRPB PANELS FACED WITH WILSONART CRYSTAL D388-60 LAMINATE. ALL PANELS ARE BANDED IN BLACK PVC EDGE BANDING	3	80.9667
4	MIDDLE WALL PANELS	HORIZONTAL PANEL SYSTEM CONSISTING OF (3) 1/2" FRPB PANELS FACED WITH WILSONART HIGH LINE 7970K-18 LAMINATE. ALL PANELS ARE BANDED IN BLACK PVC EDGE BANDING	3	80.9667
5	HANDRAIL WALL PANELS	HORIZONTAL PANEL SYSTEM CONSISTING OF (3) 1/2" FRPB PANELS FACED WITH WILSONART CRYSTAL D388-60 LAMINATE. ALL PANELS ARE BANDED IN BLACK PVC EDGE BANDING	3	23.1333
6	LOWER WALL PANELS	HORIZONTAL PANEL SYSTEM CONSISTING OF (3) 1/2" FRPB PANELS FACED WITH WILSONART HIGH LINE 7970K-18 LAMINATE. ALL PANELS ARE BANDED IN BLACK PVC EDGE BANDING	3	66.5083
7	BACK HANDRAIL	3/8" X 2.00" FLAT S/S, #4 FINISH WITH RETURNED ENDS. STANDARD, FLAT FACE STANDOFFS	1	14.1844
8	SIDE HANDRAIL	3/8" X 2.00" FLAT S/S, #4 FINISH WITH RETURNED ENDS. STANDARD, FLAT FACE STANDOFFS	2	16.3094
9	RECESSED BASE & REVEALS	20 GAUGE STAINLESS STEEL #4 FINISH	1 (SET)	22.3755



8896 West State Rd. 236  
Middletown, IN 47356  
T: 800.800.4960

F.A.C. JOB NUMBER: XXXXX	CAPACITY: 2500 lbs	JOB NAME: JOB NAME HERE
CAB I.D.: CAB XX		CONTACT: YOUR NAME HERE!
WALL PANELS: SANTA CRUZ		CEILING TYPE: ANEGADA T-FRAME
SALES REP: SALES REP NAME HERE	DATE: XX/XX/20XX	DRAWING SCALE: 1 : 25
REVISIONS:	FABRICATION APPROVAL SIGNATURE:	

SPECIFIC PRODUCT NOTES		UNIT CONVERSION	
ALL DIMENSIONS ARE GIVEN IN INCHES		1/2 = 0.5000	9/16 = 0.5625
(ALL DIMENSIONS ±1/32")		3/16 = 0.1875	11/16 = 0.6875
QTY: 1 CAB		1/4 = 0.2500	3/4 = 0.7500
		5/16 = 0.3125	13/16 = 0.8125
		3/8 = 0.3750	7/8 = 0.8750
		7/16 = 0.4375	15/16 = 0.9375