

REFLECTED CEILING VIEW
A VIEW OF THE CAB AS IF LOOKING FROM ABOVE, THROUGH THE CEILING

PLAN VIEW

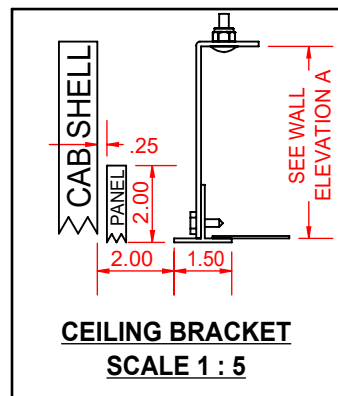

PARTS LIST & FINISH SELECTION				
ITEM	DESCRIPTION	MATERIAL	QTY	WEIGHT / lbs
1	CEILING	ANEGADA: BRUSHED ALUMINUM T-FRAME (1.50"X1.50"X.125") CEILING COATED IN CLEAR LACQUER WITH (6) 14 GAUGE STAINLESS STEEL #4 FINISH DROP IN PANELS	1	85.679
2	LIGHTING	SOLOBEAM-6: LED DOWN LIGHTING SYSTEM BY MAN-D-TEC. DIE-CAST SMOOTH BLACK FINISH FIXTURES	1 (SET)	8.6642
3	INTERIOR PANELS	VERTICAL PANEL SYSTEM CONSISTING OF (7) 1/2" FRPB WALL PANELS FACED WITH WILSONART BILTMORE CHERRY 7924K-07 LAMINATE. ALL PANELS ARE BANDED IN CLEAR ANODIZED BRUSHED ALUMINUM CAPTURING FRAME	7	272.4853
4	BACK HANDRAIL	0.375" X 2.00" FLAT S/S, #4 FINISH WITH RETURNED ENDS. PATENTED, FLAT FACE STANDOFFS	1	14.1844
5	SIDE HANDRAILS	0.375" X 2.00" FLAT S/S, #4 FINISH WITH RETURNED ENDS. PATENTED, FLAT FACE STANDOFFS	2	16.3094
6	RECESSED BASE & REVEALS	20 GAUGE STAINLESS STEEL #4 FINISH	1 (SET)	29.5995

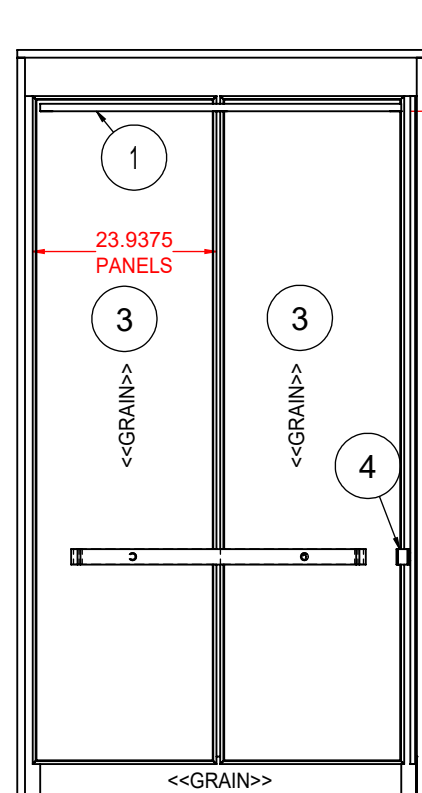

WALL ELEVATION A

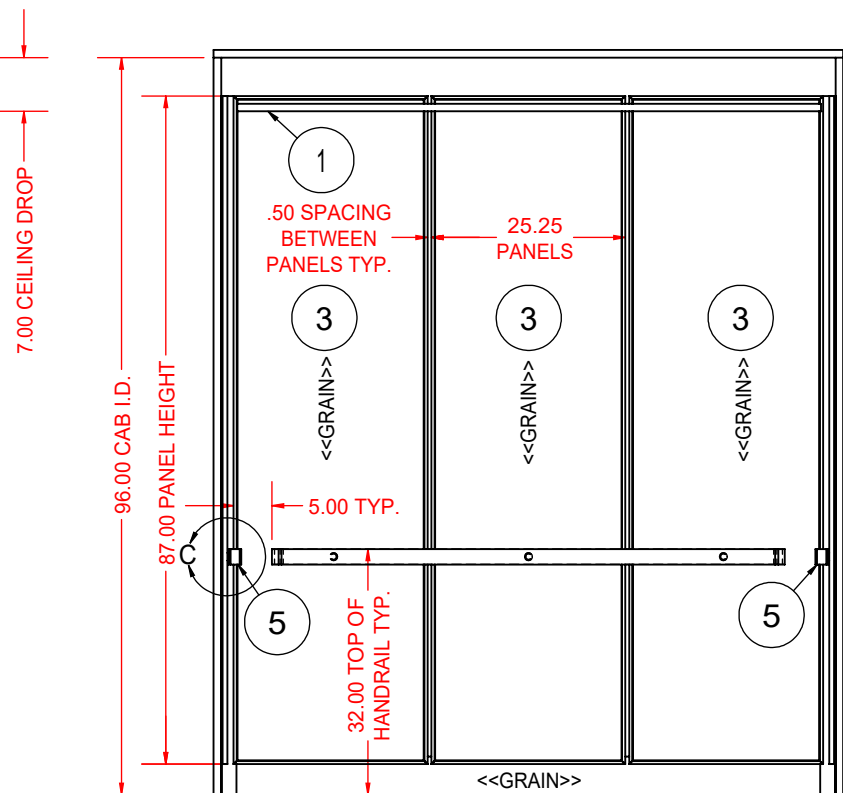

WALL ELEVATION B

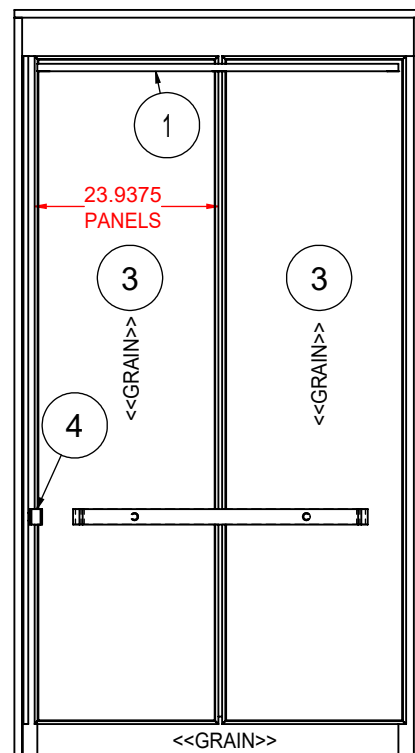

WALL ELEVATION C

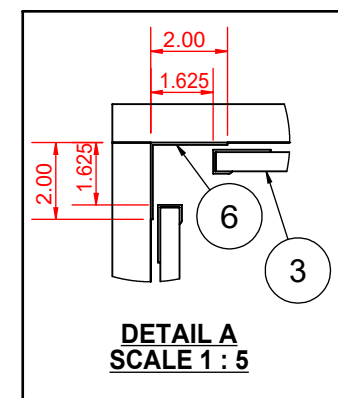

DETAIL A SCALE 1:5

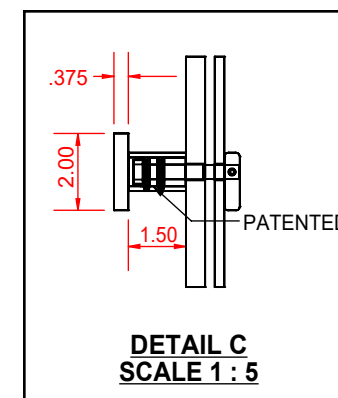

DETAIL C SCALE 1:5

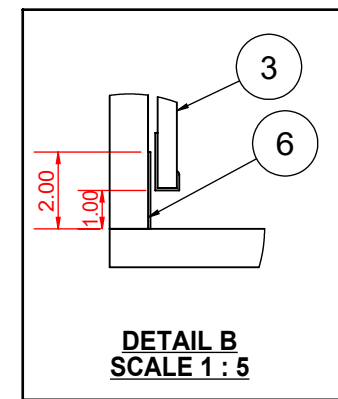

DETAIL B SCALE 1:5

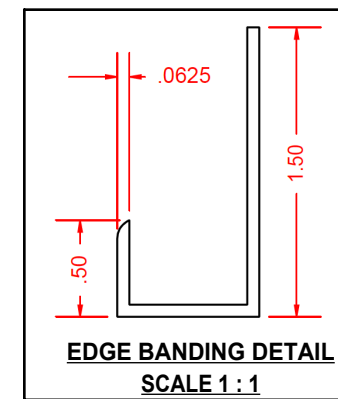

EDGE BANDING DETAIL SCALE 1:1



8896 West State Rd. 236 Middletown, IN 47356
T: 800.800.4960

F.A.C. JOB NUMBER: XXXXX	CAPACITY: 2500 lbs	JOB NAME: JOB NAME HERE	SPECIFIC PRODUCT NOTES ALL DIMENSIONS ARE GIVEN IN INCHES (ALL DIMENSIONS ±1/32") QTY: 1 CAB	UNIT CONVERSION 1/2 = 0.5000 1/8 = 0.1250 9/16 = 0.5625 3/16 = 0.1875 5/8 = 0.6250 11/16 = 0.6875 1/4 = 0.2500 3/4 = 0.7500 5/16 = 0.3125 13/16 = 0.8125 3/8 = 0.3750 7/8 = 0.8750 7/16 = 0.4375 15/16 = 0.9375
CAB I.D.: CAB XX	CONTACT: YOUR NAME HERE!	CEILING TYPE: ANEGADA T-FRAME		
SALES REP: SALES REP NAME HERE	DATE: XX/XX/20XX	DRAWING SCALE: 1 : 25	FABRICATION APPROVAL SIGNATURE:	
REVISIONS:				SHEET 1-1

1 2 3 4 5 6 7 8

PARTS LIST & FINISH SELECTION				
ITEM	DESCRIPTION	MATERIAL	QTY	WEIGHT / lbs
1	CEILING	ANEGADA: BRUSHED ALUMINUM T-FRAME (1.50"X1.50"X.125") CEILING COATED IN CLEAR LACQUER WITH (6) 14 GAUGE STAINLESS STEEL #4 FINISH DROP IN PANELS	1	85.679
2	LIGHTING	SOLOBEAM-6: LED DOWN LIGHTING SYSTEM BY MAN-D-TEC. DIE-CAST SMOOTH BLACK FINISH FIXTURES	1 (SET)	8.6642
3	INTERIOR PANELS	VERTICAL PANEL SYSTEM CONSISTING OF (7) 1/2" FRPB WALL PANELS FACED WITH WILSONART BILTMORE CHERRY 7924K-07 LAMINATE. ALL PANELS ARE BANDED IN CLEAR ANODIZED BRUSHED ALUMINUM CAPTURING FRAME	7	272.4853
4	BACK HANDRAIL	0.375" X 2.00" FLAT S/S, #4 FINISH WITH RETURNED ENDS. PATENTED, FLAT FACE STANDOFFS	1	14.1844
5	SIDE HANDRAILS	0.375" X 2.00" FLAT S/S, #4 FINISH WITH RETURNED ENDS. PATENTED, FLAT FACE STANDOFFS	2	16.3094
6	RECESSED BASE & REVEALS	20 GAUGE STAINLESS STEEL #4 FINISH	1 (SET)	29.5995



IMAGE FOR ILLUSTRATION
PURPOSES ONLY,
COLOR SHADES AND
PROPORTIONS MAY VARY

 <p>8896 West State Rd. 236 Middletown, IN 47356</p> <p>T: 800.800.4960</p>	F.A.C. JOB NUMBER: XXXXX	CAPACITY: 2500 lbs	JOB NAME: JOB NAME HERE	SPECIFIC PRODUCT NOTES ALL DIMENSIONS ARE GIVEN IN INCHES (ALL DIMENSIONS ±1/32") QTY: 1 CAB	UNIT CONVERSION 1/2 = 0.5000 1/8 = 0.1250 9/16 = 0.5625 3/16 = 0.1875 5/8 = 0.6250 1/4 = 0.2500 11/16 = 0.6875 5/16 = 0.3125 3/4 = 0.7500 3/8 = 0.3750 13/16 = 0.8125 7/16 = 0.4375 7/8 = 0.8750 15/16 = 0.9375
	CAB I.D.: CAB XX	CONTACT: YOUR NAME HERE!	CEILING TYPE: ANEGADA T-FRAME		
	WALL PANELS: FREEPORT	DATE: XX/XX/20XX	DRAWING SCALE: 1 : 25		
	SALES REP: SALES REP NAME HERE	FABRICATION APPROVAL SIGNATURE:			
	REVISIONS:				

1 2 3 4 5 6 7 8